



SPEC SHEET

# Steam Table Drop In



PROJECT: \_\_\_\_\_

ITEM #: \_\_\_\_\_

MODEL: \_\_\_\_\_

## Standard Features

- Installs in your new or existing counter
- 3' standard conduit length
- Wet or dry operation
- Hard wire connection
- Each well holds 1 - 12" x 20" food pan or fractional equivalent
- Manifold drain
- Drain caps
- Twist counter locking system

## Specifications

Self contained heated drop in. Top made from 18 gauge 304 stainless steel finish #4 with 3/8" edge turned down.

Fully insulated urethane foam for energy savings and efficiency.

Each well has its own independent infinite controls with individual temperature ready indicator lights. High limit prevents overheating.

Drop ins are also available in slimline configuration.

## Options

- Cord and plug; specify length
- Control panel conduit length; specify length
- Adapter bar set

ITEM	MODEL	WIDTH	DEPTH	HEIGHT	VOLT	Hz.	REQUIREMENT	CORD	PLUG
C0968	STD11	16"	24"	10-1/8"	208	60	1Ø 20 AMP	6'	NEMA 6-20
C0999	STD12	30"	24"	10-1/8"	208	60	1Ø 20 AMP	6'	NEMA 6-20
C0970	STD13	44"	24"	10-1/8"	208	60	1Ø 20 AMP	6'	NEMA 6-20
C0998	STD14	58"	24"	10-1/8"	208	60	1Ø 30 AMP	6'	NEMA 6-30
C0989	STD15	72"	24"	10-1/8"	208	60	1Ø 30 AMP	6'	NEMA 6-30



Conforms to UL Std. 197 and NSF/ANSI Std. 4  
Certified to CSA Std. C 22.2 #109

Rev 04/2026



# Steam Table Drop In

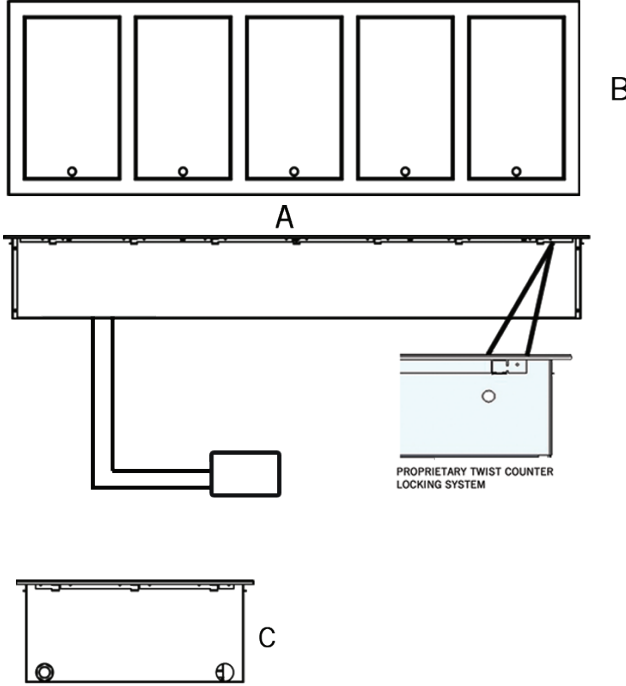

A = WIDTH  
B = DEPTH

## CONTROLS CUTOUT

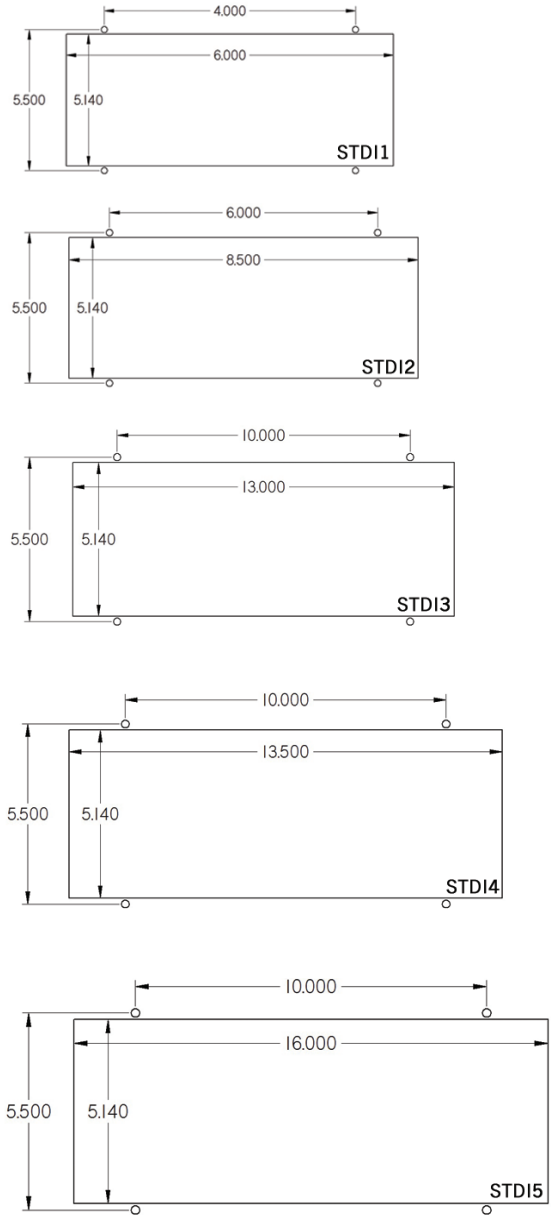

### UNIT

MODEL	WIDTH	DEPTH	HEIGHT	VOLT	Hz.	REQUIREMENT	CORD	PLUG
STD11	16"	24"	10-1/8"	208	60	1Ø 20 AMP	6'	NEMA 6-20
STD12	30"	24"	10-1/8"	208	60	1Ø 20 AMP	6'	NEMA 6-20
STD13	44"	24"	10-1/8"	208	60	1Ø 20 AMP	6'	NEMA 6-20
STD14	58"	24"	10-1/8"	208	60	1Ø 30 AMP	6'	NEMA 6-30
STD15	72"	24"	10-1/8"	208	60	1Ø 30 AMP	6'	NEMA 6-30

### COUNTER CUTOUT

WIDTH	DEPTH
14-5/8"	22-5/8"
28-5/8"	22-5/8"
42-5/8"	22-5/8"
56-5/8"	22-5/8"
70-5/8"	22-5/8"

### CONTROLS CUTOUT

WIDTH	HEIGHT
9-1/2"	5-3/16"
9-1/2"	5-3/16"
14"	5-3/16"
14"	5-3/16"
17"	5-3/16"